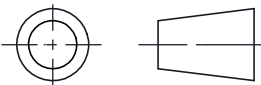

NAME PLATE DATA:

OUTPUT POWER - 400 HP (300 kW) | 450 HP (335 kW)
 INPUT VOLTAGE - 575V
 INPUT FREQUENCY - 40Hz
 FULL LOAD CURRENT - 350 A | 400 A
 NO LOAD CURRENT - 100 A
 PHASE - 3
 POLES - 4
 RATED SPEED - 1172 RPM | 1168 RPM
 MAX. MECHANICAL SPPED - 2340 RPM
 IP RATING (FRAME/JBOX) - IP23
 IC - 37
 DE BEARING - NU2222 (ROLLER)
 NDE BEARING - 6317 (BALL)
 OUTPUT TORQUE - 1,795 lbf-ft (2,490 N-m) | 2,025 lbf-ft (2,745 N-m)
 WEIGHT (as shown) - 2800 lb (1270 kg)
 REQUIRED COOLING AIR - 700 CFM | 900 CFM AT ~4.0 SPWG | ~6.6 SPWG

ANSI-INCH TOLERANCES UNLESS OTHERWISE SPECIFIED: Linear Dimensions: X ± 1/16" X/Y ± 1/16" X.X ± 0.04 X.XX ± 0.02 X.XXX ± 0.005 Angular Dimensions: X ± 1° X.X ± 0.5°	©2014  Ward Leonard <small>Excellence in Motor and Control Solutions</small> Ward Leonard - CT, LLC Thomaston, CT 06787 DRAWN DATE: 10/16/2014	THIS DOCUMENT CONTAINS TECHNICAL DATA WHICH IS THE PROPERTY OF WARD LEONARD - CT, LLC. THIS DOCUMENT AND/OR THE INFORMATION CONTAINED THEREIN SHALL NOT BE DUPLICATED, USED OR DISCLOSED IN WHOLE OR IN PART FOR THE MANUFACTURE OR PROCUREMENT OF ANY ITEM OR ITEMS SHOWN ON OR THEREBY, NOR BE PUBLISHED FOR DISTRIBUTION OUTSIDE UNITED STATES MILITARY ESTABLISHMENT WITHOUT THE WRITTEN CONSENT OF WARD LEONARD - CT, LLC. THIS LEGEND SHALL BE INCLUDED ON ANY DUPLICATION THEREOF IN WHOLE OR IN PART.		
	REFERENCE ONLY	TITLE 400HP 450 HP AC Induction Motor		
 THIRD ANGLE PROJECTION	SIZE B	DWG NO WL250040 WL250045	REV -	
SCALE: 1:16		SHEET 1 OF 1		