

B

B

A

A

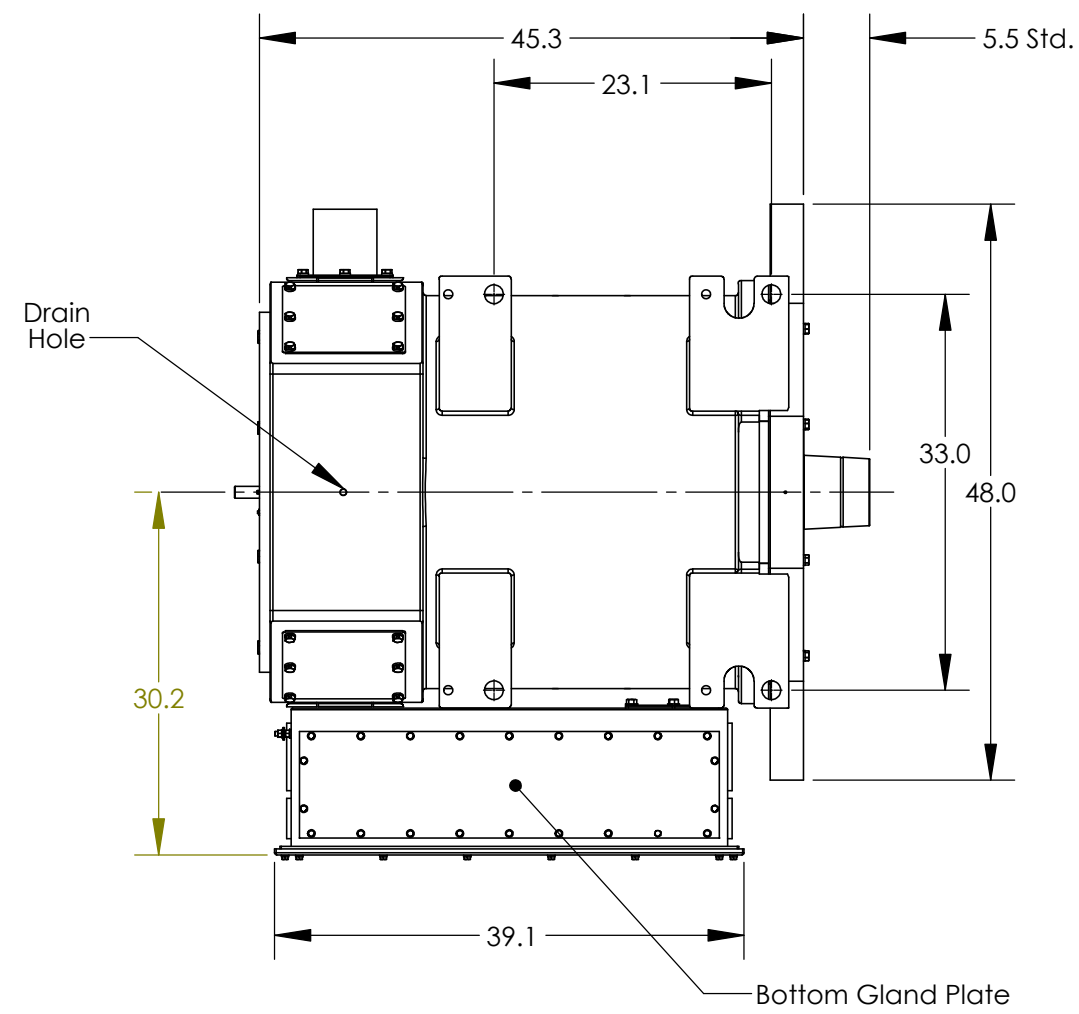
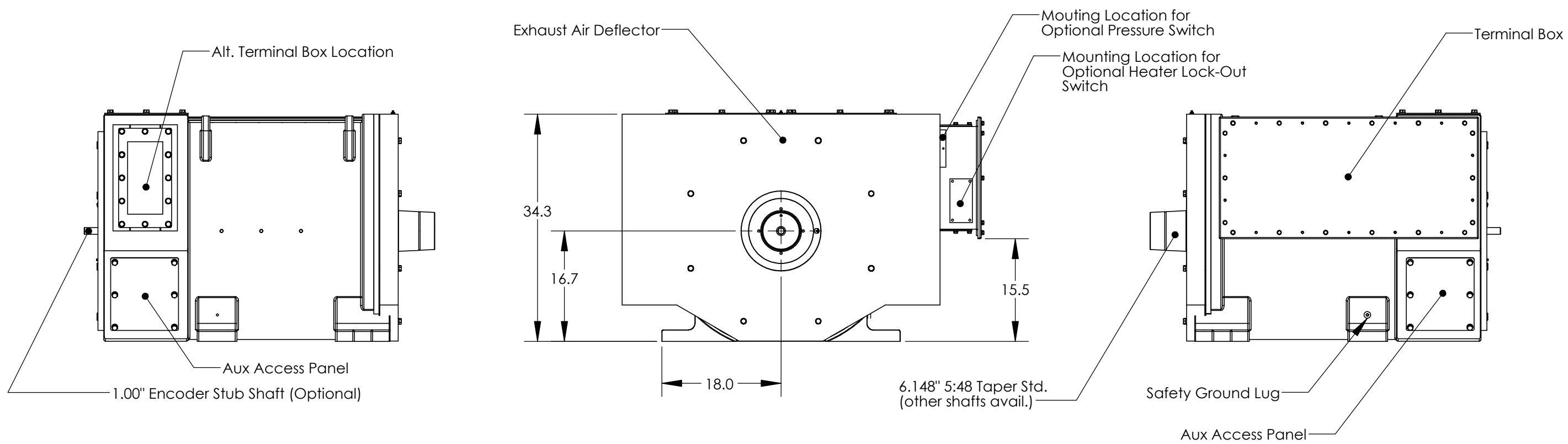

**NAME PLATE DATA:**

OUTPUT POWER - 1500HP (1120 kW)  
 INPUT VOLTAGE - 550V  
 INPUT FREQUENCY - 40Hz  
 FULL LOAD CURRENT - 1630 A  
 NO LOAD CURRENT - 880 A  
 PHASE - 3  
 POLES - 6  
 RATED SPEED - 785 RPM  
 MAX. MECHANICAL SPPED - 3000 RPM  
 IP RATING (FRAME/JBOX) - IP44/IP56  
 IC - 06  
 DE BEARING - NU332ECMA (ROLLER) or 6332M (BALL)  
 NDE BEARING - 6326M  
 OUTPUT TORQUE - 10,035 lbf-ft (13,605 N-m)  
 WEIGHT (as shown) - 7500 lb (3400 kg)  
 REQUIRED COOLING AIR - 3250 CFM AT ~16.0 SPWG

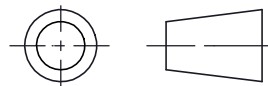
|  |   |   |          |
|--|---|---|----------|
| <b>ANSI-INCH TOLERANCES UNLESS OTHERWISE SPECIFIED:</b><br>Linear Dimensions:<br>X ± 1/16"<br>X/Y ± 1/16"<br><br>X.X ± 0.04<br>X.XX ± 0.02<br>X.XXX ± 0.005<br><br>Angular Dimensions:<br>X ± 1°<br>X.X ± 0.5° | ©2014  <b>Ward Leonard</b><br><i>Excellence in Motor and Control Solutions</i><br>Ward Leonard - CT, LLC<br>Thomaston, CT 06787<br>DRAWN DATE: 5/20/2014 | THIS DOCUMENT CONTAINS TECHNICAL DATA WHICH IS THE PROPERTY OF WARD LEONARD - CT, LLC. THIS DOCUMENT AND/OR THE INFORMATION CONTAINED THEREIN SHALL NOT BE DUPLICATED, USED OR DISCLOSED IN WHOLE OR IN PART FOR THE MANUFACTURE OR PROCUREMENT OF ANY ITEM OR ITEMS SHOWN ON OR THEREBY, NOR BE PUBLISHED FOR DISTRIBUTION OUTSIDE UNITED STATES MILITARY ESTABLISHMENT WITHOUT THE WRITTEN CONSENT OF WARD LEONARD - CT, LLC. THIS LEGEND SHALL BE INCLUDED ON ANY DUPLICATION THEREOF IN WHOLE OR IN PART. |          |
|  | <b>REFERENCE ONLY</b>   | TITLE<br><b>1500HP AC Induction Motor</b>   |          |
| THIRD ANGLE PROJECTION    | SIZE<br>B   | DWG NO<br>WL29BC150-H   | REV<br>- |
| SCALE: 1:16  |   | SHEET 1 OF 3  |          |

B

B

A

A

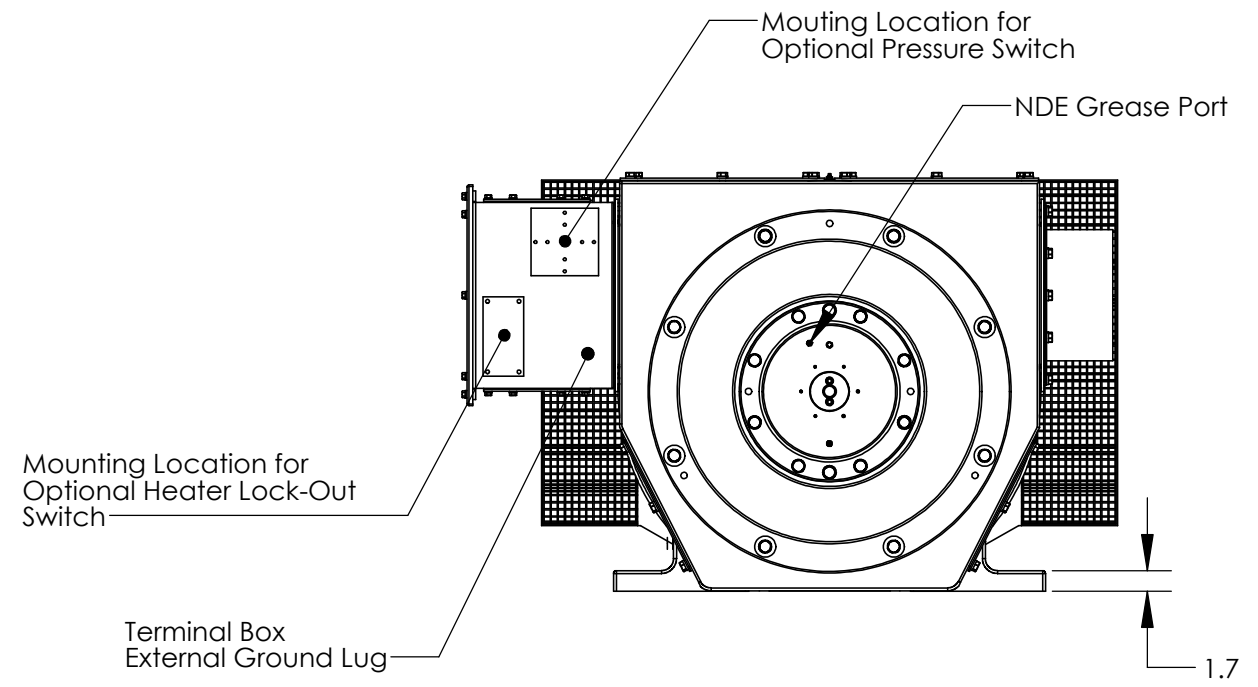
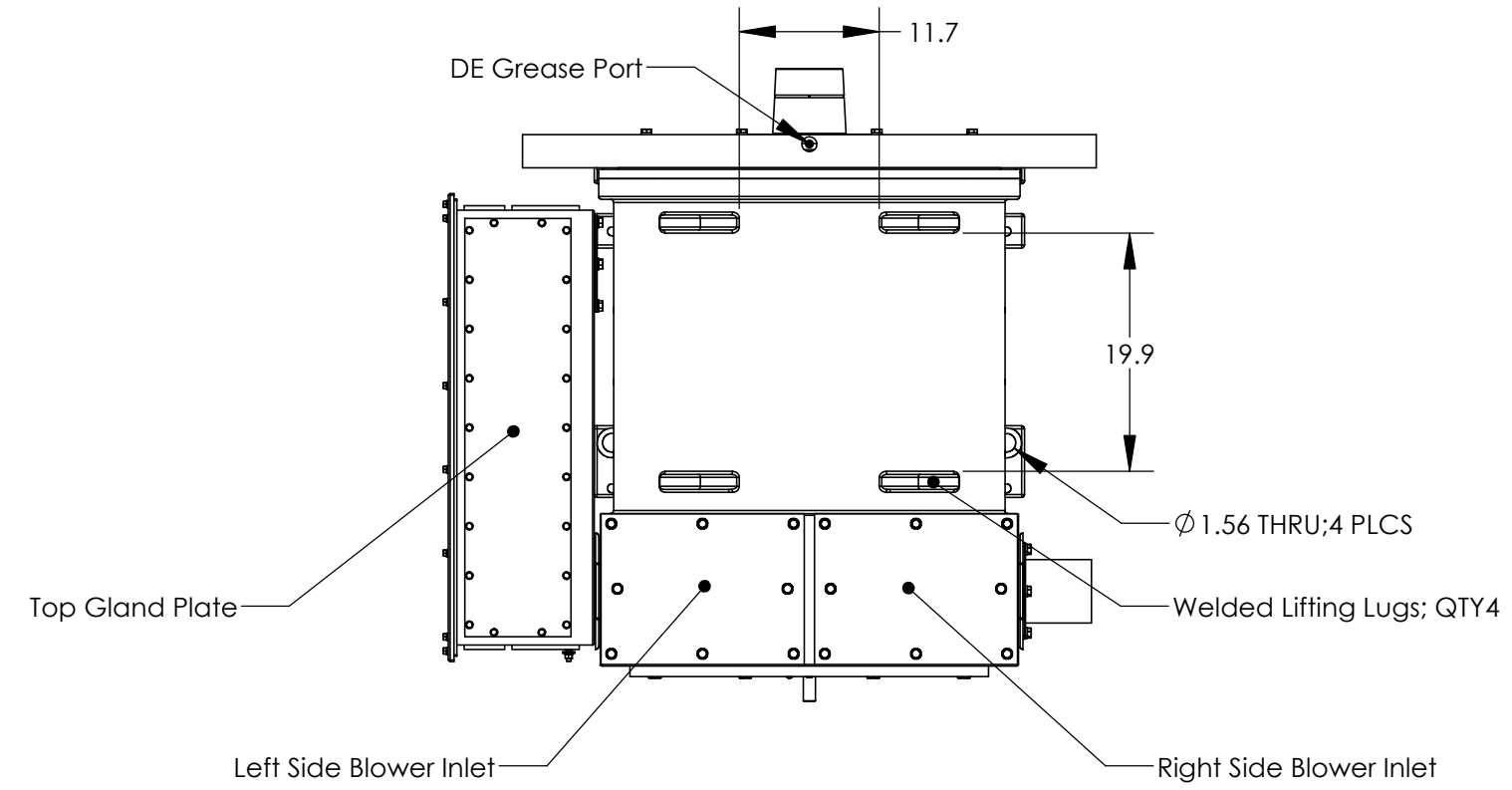

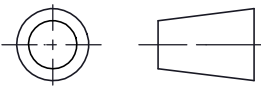
|  |   |   |          |             |
|--|---|---|----------|-------------|
| <b>ANSI-INCH</b><br><b>TOLERANCES UNLESS OTHERWISE SPECIFIED:</b><br>Linear Dimensions:<br>X ± 1/16"<br>X/Y ± 1/16"<br><br>X.X ± 0.04<br>X.XX ± 0.02<br>X.XXX ± 0.005<br><br>Angular Dimensions:<br>X ± 1°<br>X.X ± 0.5° | ©2014  <b>Ward Leonard</b><br><small>Excellence in Motor and Control Solutions</small><br>Ward Leonard - CT, LLC<br>Thomaston, CT 06787<br>DRAWN DATE: 5/20/2014 | THIS DOCUMENT CONTAINS TECHNICAL DATA WHICH IS THE PROPERTY OF WARD LEONARD - CT, LLC. THIS DOCUMENT AND/OR THE INFORMATION CONTAINED THEREIN SHALL NOT BE DUPLICATED, USED OR DISCLOSED IN WHOLE OR IN PART FOR THE MANUFACTURE OR PROCUREMENT OF ANY ITEM OR ITEMS SHOWN ON OR THEREBY, NOR BE PUBLISHED FOR DISTRIBUTION OUTSIDE UNITED STATES MILITARY ESTABLISHMENT WITHOUT THE WRITTEN CONSENT OF WARD LEONARD - CT, LLC. THIS LEGEND SHALL BE INCLUDED ON ANY DUPLICATION THEREOF IN WHOLE OR IN PART. |          |             |
|  | <b>REFERENCE ONLY</b>   | TITLE<br><b>1500HP AC Induction Motor</b>   |          |             |
| THIRD ANGLE PROJECTION    | SIZE<br>B   | DWG NO<br>WL29BC150-H   | REV<br>- | SCALE: 1:16 |
|  |   | SHEET 2 OF 3  |          |             |



### TLNDE-NO

Blower Configuration  
 - Top-Left from Non-Drive End (TLNDE)  
 - Normal Orientation (NO)

### RLNDE-NO

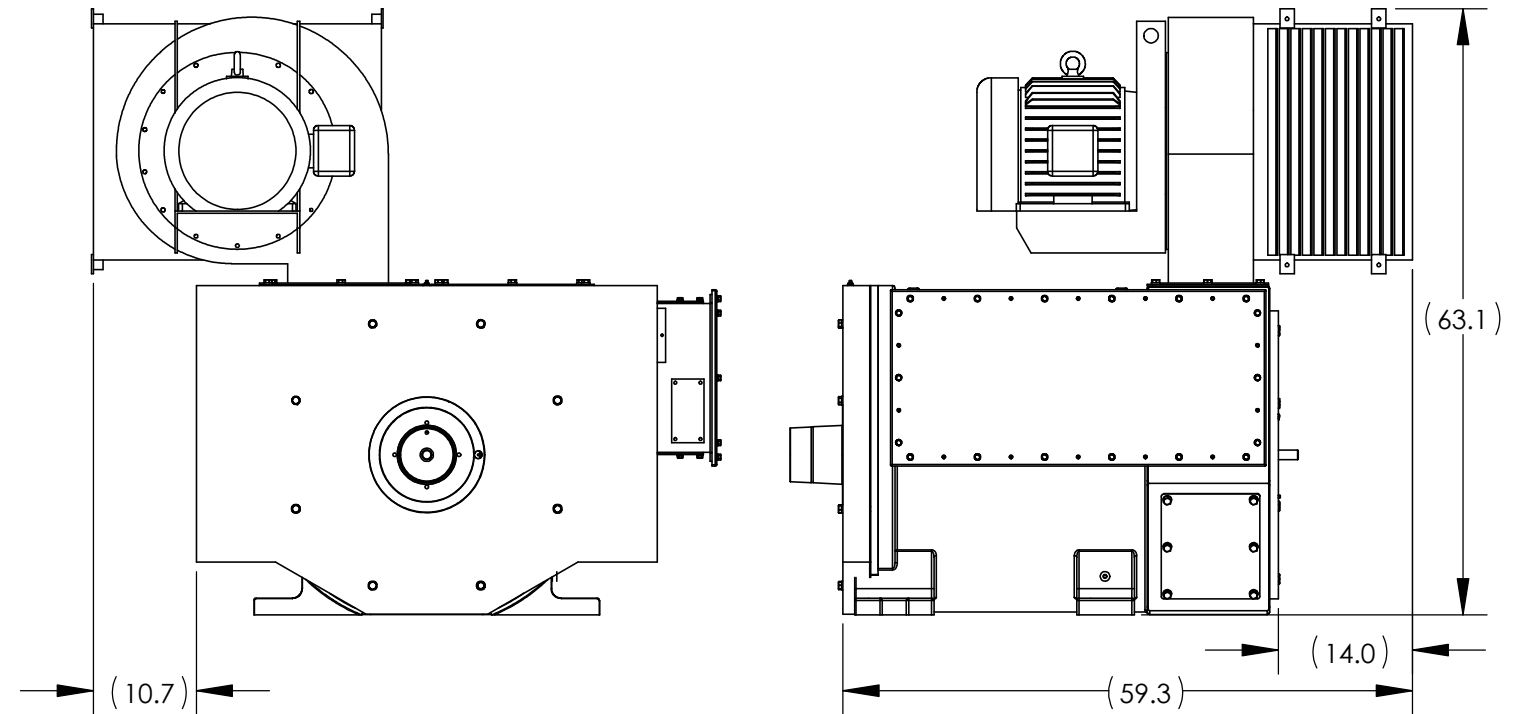
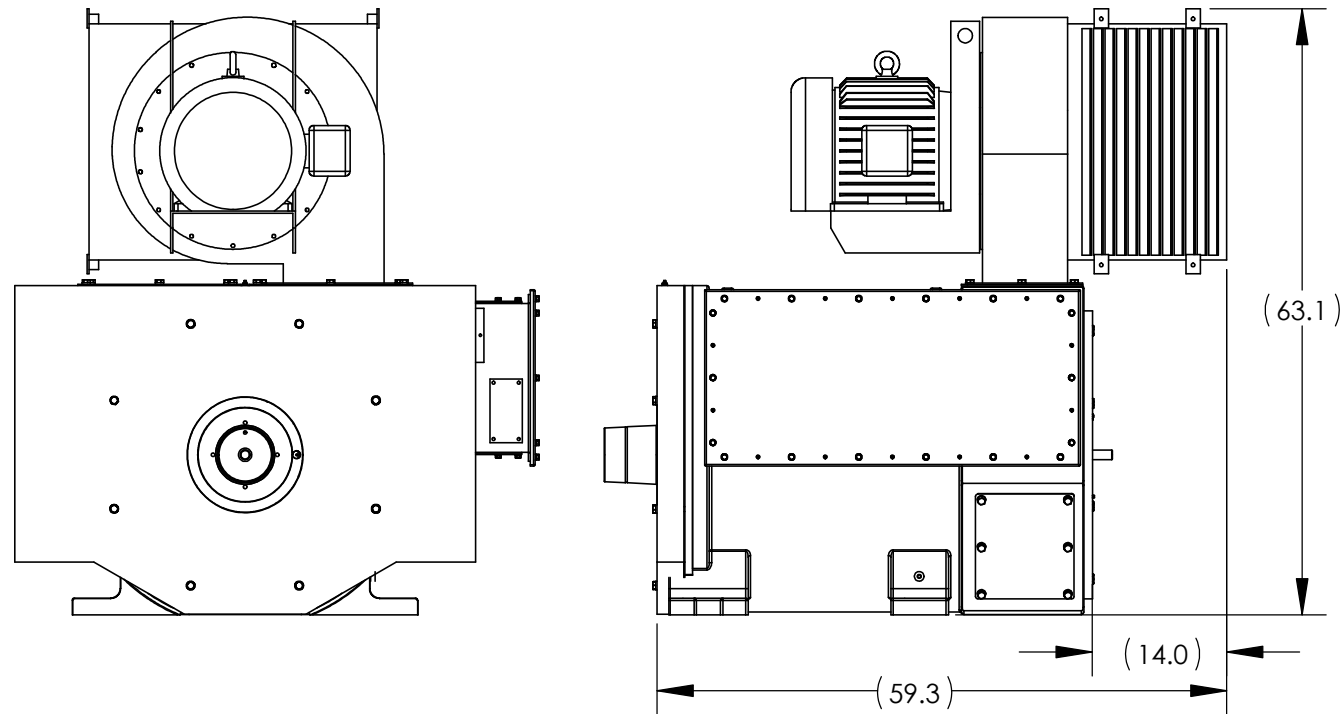
Blower Configuration  
 - Top-Right from Non-Drive End (TLNDE)  
 - Normal Orientation (NO)



|  |   |   |              |  |
|--|---|---|--------------|--|
| <b>ANSI-INCH</b><br><b>TOLERANCES UNLESS OTHERWISE SPECIFIED:</b><br>Linear Dimensions:<br>X ± 1/16"<br>X/Y ± 1/16"<br><br>X.X ± 0.04<br>X.XX ± 0.02<br>X.XXX ± 0.005<br><br>Angular Dimensions:<br>X ± 1°<br>X.X ± 0.5° | ©2014  <b>Ward Leonard</b><br><i>Excellence in Motor and Control Solutions</i><br>Ward Leonard - CT, LLC<br>Thomaston, CT 06787<br>DRAWN DATE: 5/20/2014 | THIS DOCUMENT CONTAINS TECHNICAL DATA WHICH IS THE PROPERTY OF WARD LEONARD - CT, LLC. THIS DOCUMENT AND/OR THE INFORMATION CONTAINED THEREIN SHALL NOT BE DUPLICATED, USED OR DISCLOSED IN WHOLE OR IN PART FOR THE MANUFACTURE OR PROCUREMENT OF ANY ITEM OR ITEMS SHOWN ON OR THEREBY, NOR BE PUBLISHED FOR DISTRIBUTION OUTSIDE UNITED STATES MILITARY ESTABLISHMENT WITHOUT THE WRITTEN CONSENT OF WARD LEONARD - CT, LLC. THIS LEGEND SHALL BE INCLUDED ON ANY DUPLICATION THEREOF IN WHOLE OR IN PART. |              |  |
|  | <b>REFERENCE ONLY</b><br>  | TITLE<br><b>1500HP AC Induction Motor</b>   |              |  |
|  | SIZE<br>B   | DWG NO<br>WL29BC150-H   | REV<br>-     |  |
|  | SCALE: 1:16   |   | SHEET 3 OF 3 |  |