

B

B

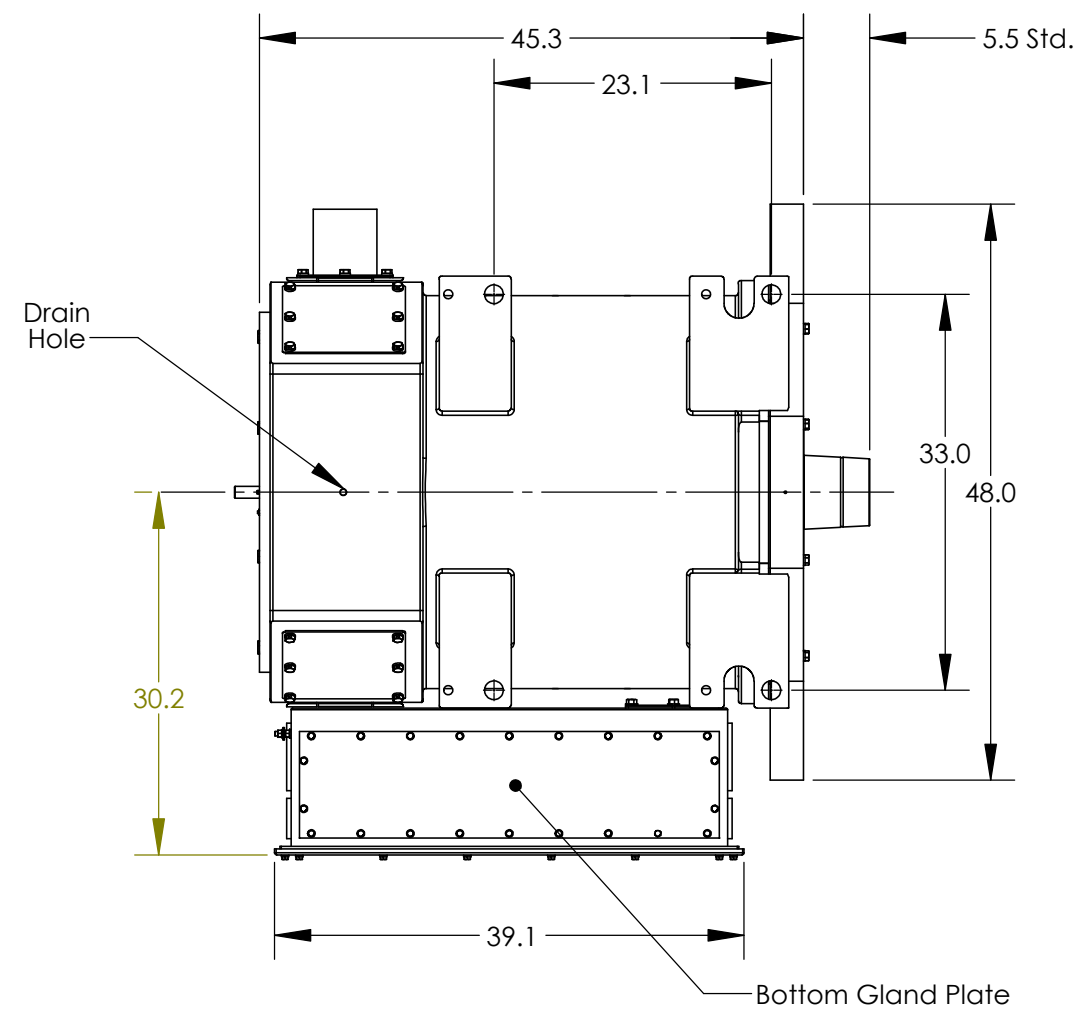
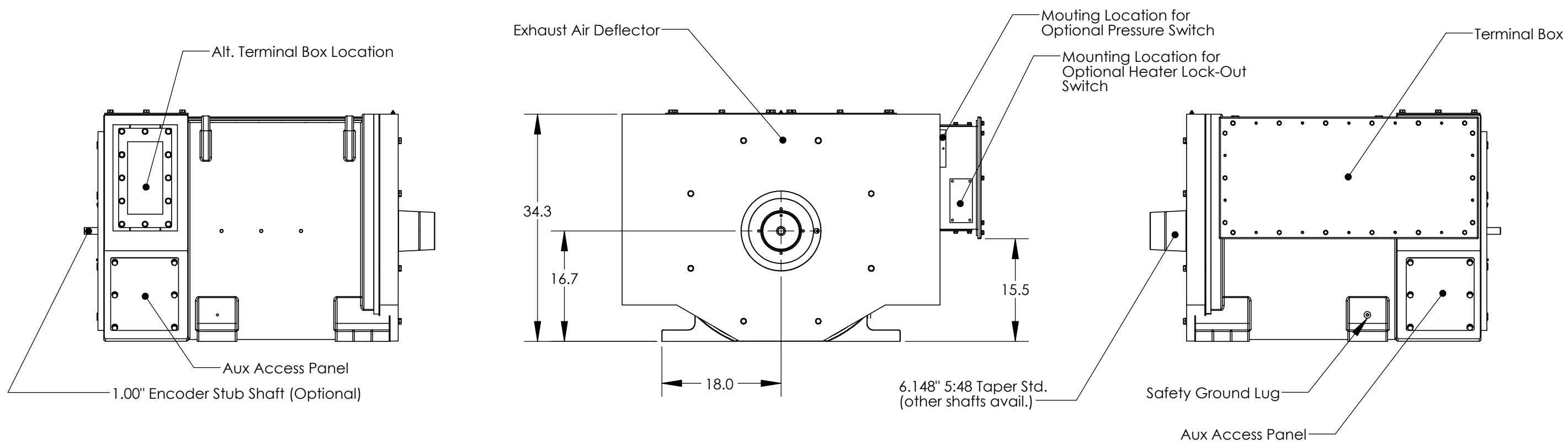

A

A



**NAME PLATE DATA:**

OUTPUT POWER - 1600HP (1195 kW)  
 INPUT VOLTAGE - 550V  
 INPUT FREQUENCY - 45Hz  
 FULL LOAD CURRENT - 1590 A  
 NO LOAD CURRENT - 630 A  
 PHASE - 3  
 POLES - 6  
 RATED SPEED - 887 RPM  
 MAX. MECHANICAL SPPED - 3000 RPM  
 IP RATING (FRAME/JBOX) - IP44/IP56  
 IC - 06  
 DE BEARING - NU332ECMA (ROLLER) or 6332M (BALL)  
 NDE BEARING - 6326M  
 OUTPUT TORQUE - 9,500 lbf-ft (12,880 N-m)  
 WEIGHT (as shown) - 7500 lb (3400 kg)  
 REQUIRED COOLING AIR - 3250 CFM AT ~15.0 SPWG

<b>ANSI-INCH TOLERANCES UNLESS OTHERWISE SPECIFIED:</b> Linear Dimensions: X ± 1/16" X/Y ± 1/16"  X.X ± 0.04 X.XX ± 0.02 X.XXX ± 0.005  Angular Dimensions: X ± 1° X.X ± 0.5°	©2014  <b>Ward Leonard</b> <i>Excelsior in Motor and Control Solutions</i> Ward Leonard - CT, LLC Thomaston, CT 06787 DRAWN DATE: 5/20/2014	THIS DOCUMENT CONTAINS TECHNICAL DATA WHICH IS THE PROPERTY OF WARD LEONARD - CT, LLC. THIS DOCUMENT AND/OR THE INFORMATION CONTAINED THEREIN SHALL NOT BE DUPLICATED, USED OR DISCLOSED IN WHOLE OR IN PART FOR THE MANUFACTURE OR PROCUREMENT OF ANY ITEM OR ITEMS SHOWN ON OR THEREBY, NOR BE PUBLISHED FOR DISTRIBUTION OUTSIDE UNITED STATES MILITARY ESTABLISHMENT WITHOUT THE WRITTEN CONSENT OF WARD LEONARD - CT, LLC. THIS LEGEND SHALL BE INCLUDED ON ANY DUPLICATION THEREOF IN WHOLE OR IN PART.	
	<b>REFERENCE ONLY</b>	TITLE <b>1600HP AC Induction Motor</b>	
 THIRD ANGLE PROJECTION	SIZE B	DWG NO WL29BC160-H	REV -
SCALE: 1:16		SHEET 1 OF 2	

B

B

A

A

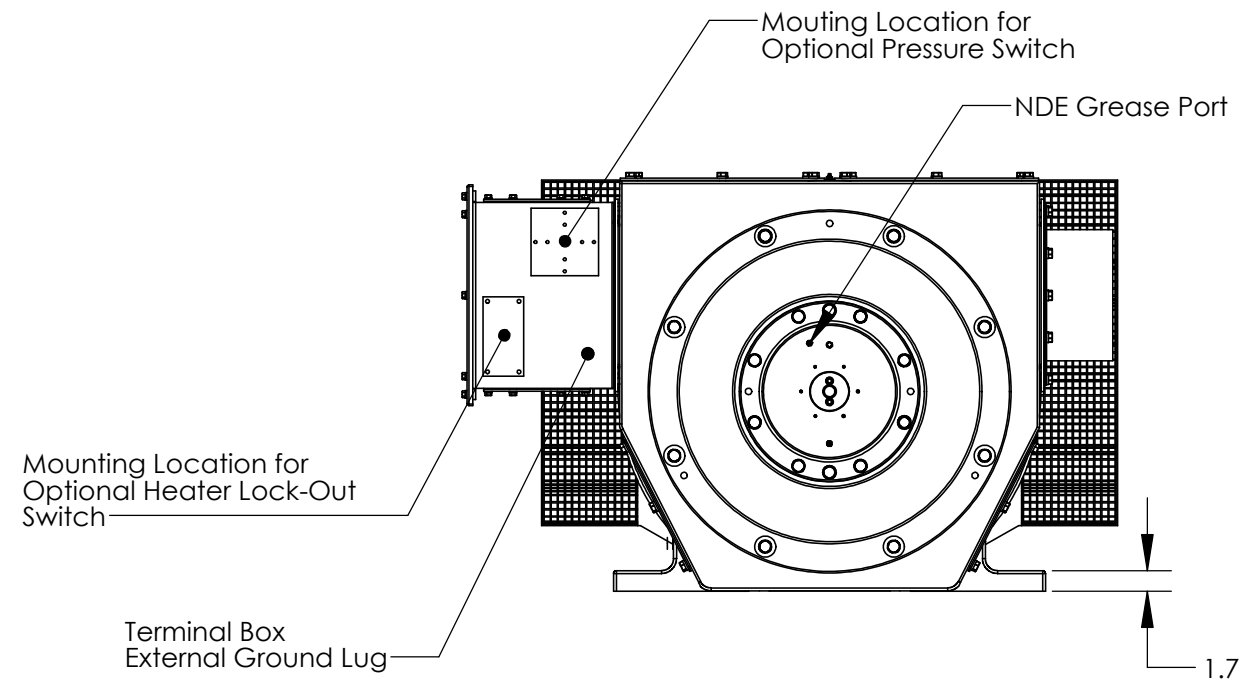
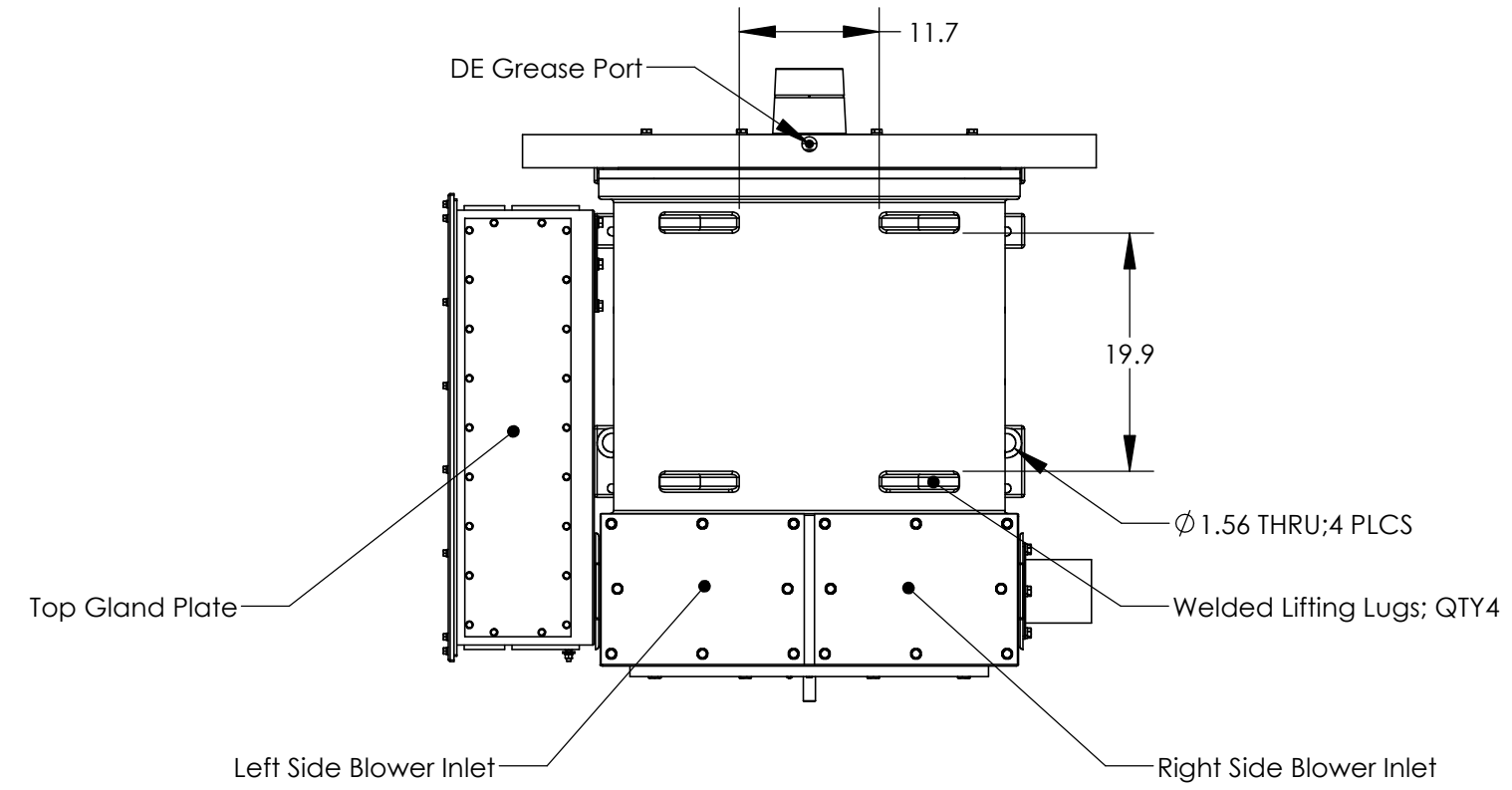

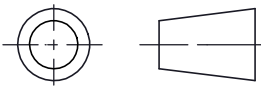
<b>ANSI-INCH</b> <b>TOLERANCES UNLESS OTHERWISE SPECIFIED:</b> Linear Dimensions: X ± 1/16" X/Y ± 1/16"  X.X ± 0.04 X.XX ± 0.02 X.XXX ± 0.005  Angular Dimensions: X ± 1° X.X ± 0.5°	©2014  <b>Ward Leonard</b> <small>Excellence in Motor and Control Solutions</small> Ward Leonard - CT, LLC Thomaston, CT 06787 DRAWN DATE: 5/20/2014	THIS DOCUMENT CONTAINS TECHNICAL DATA WHICH IS THE PROPERTY OF WARD LEONARD - CT, LLC. THIS DOCUMENT AND/OR THE INFORMATION CONTAINED THEREIN SHALL NOT BE DUPLICATED, USED OR DISCLOSED IN WHOLE OR IN PART FOR THE MANUFACTURE OR PROCUREMENT OF ANY ITEM OR ITEMS SHOWN ON OR THEREBY, NOR BE PUBLISHED FOR DISTRIBUTION OUTSIDE UNITED STATES MILITARY ESTABLISHMENT WITHOUT THE WRITTEN CONSENT OF WARD LEONARD - CT, LLC. THIS LEGEND SHALL BE INCLUDED ON ANY DUPLICATION THEREOF IN WHOLE OR IN PART.		
	<b>REFERENCE ONLY</b>	<b>TITLE</b> 1600HP AC Induction Motor		
THIRD ANGLE PROJECTION 	<b>SIZE</b> B	<b>DWG NO</b> WL29BC160-H	<b>REV</b> -	<b>SCALE:</b> 1:16
		<b>SHEET 2 OF 2</b>		